

Electric Circuit for Physicists

電子回路論 第9回

Figure part

東京大学理学部・理学系研究科

物性研究所

勝本信吾

Shingo Katsumoto

Characteristic impedance

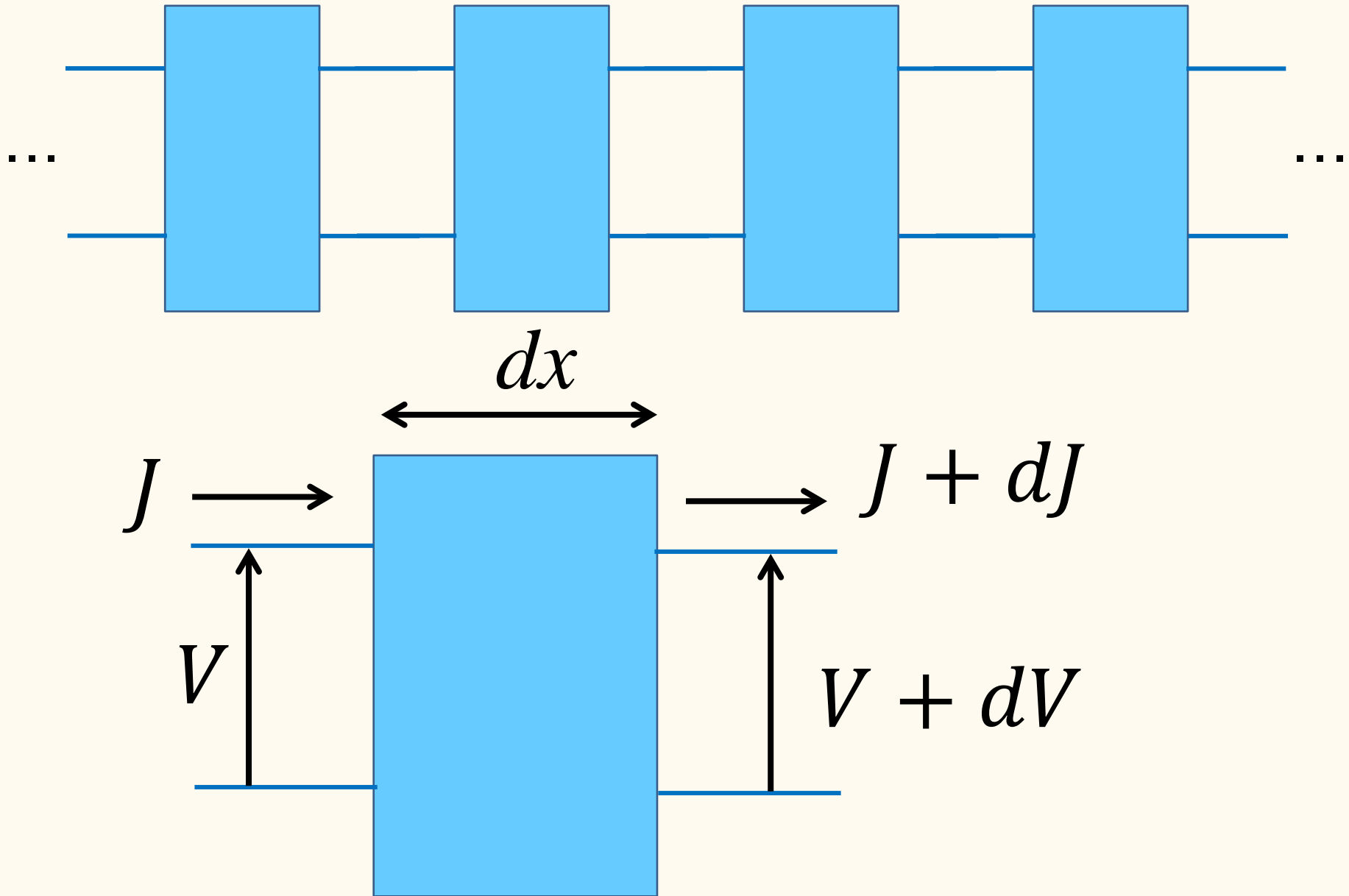

Pure reactance transmission line

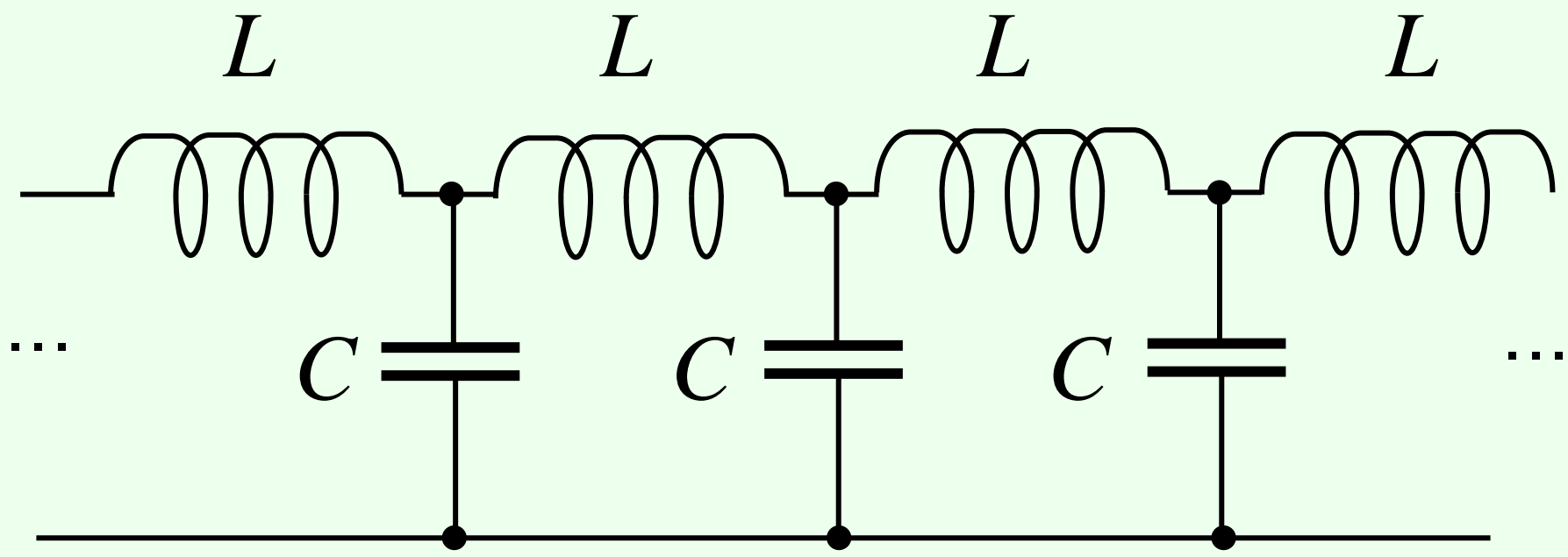

Coaxial cable setup

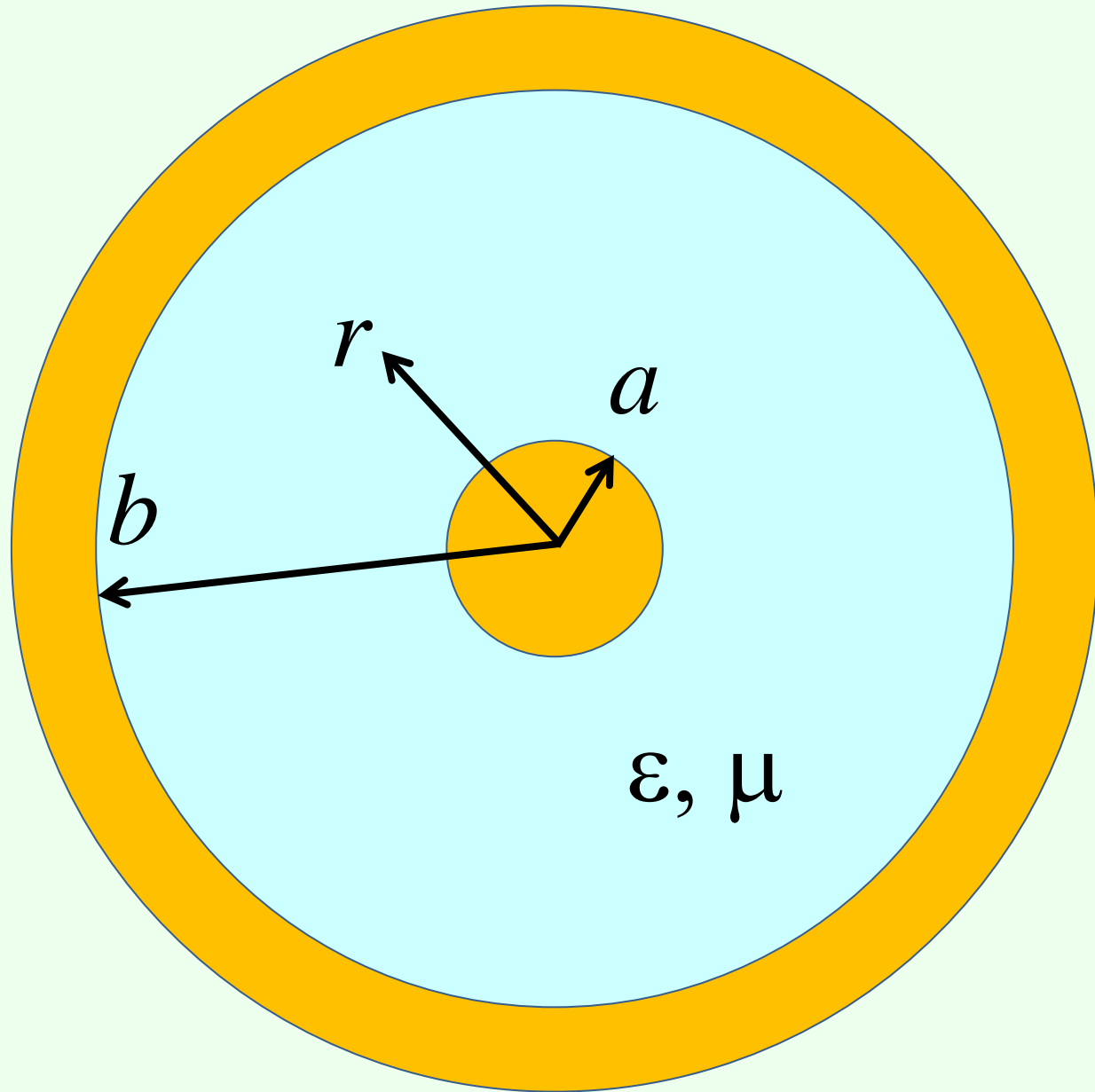

Connection and termination

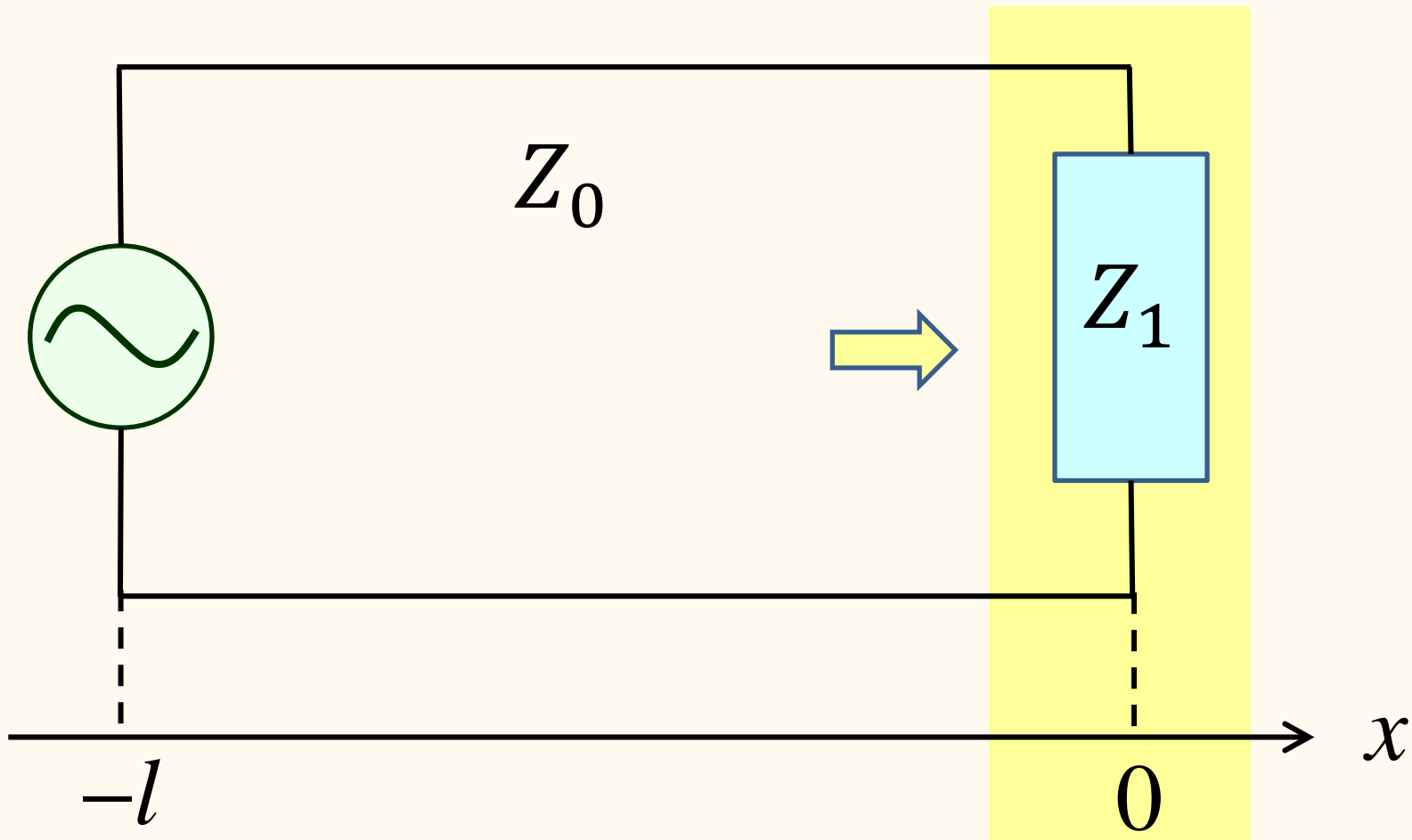

SWR measurement

SWR Meters:

Desktop types



Cross-meter

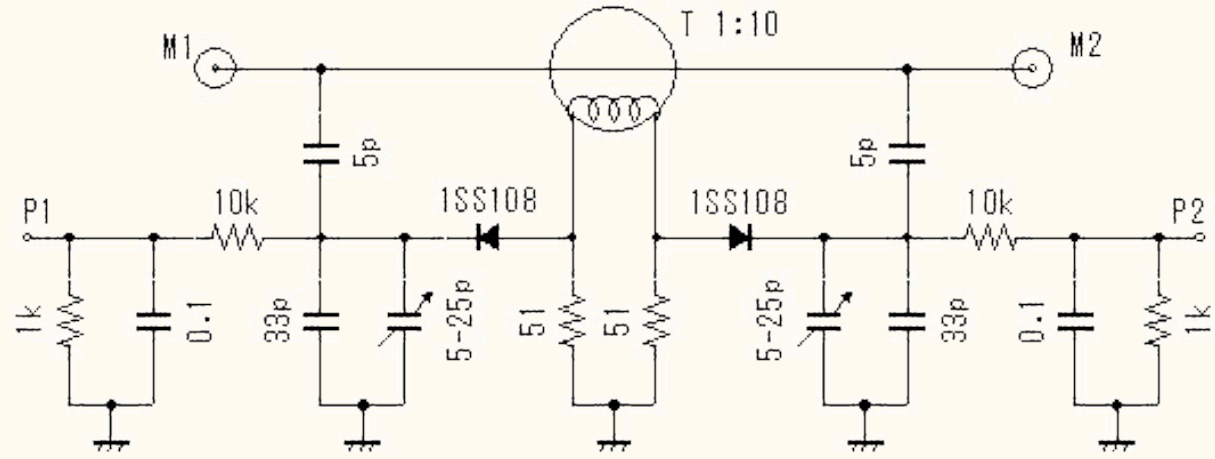

Handy type

Connection and termination

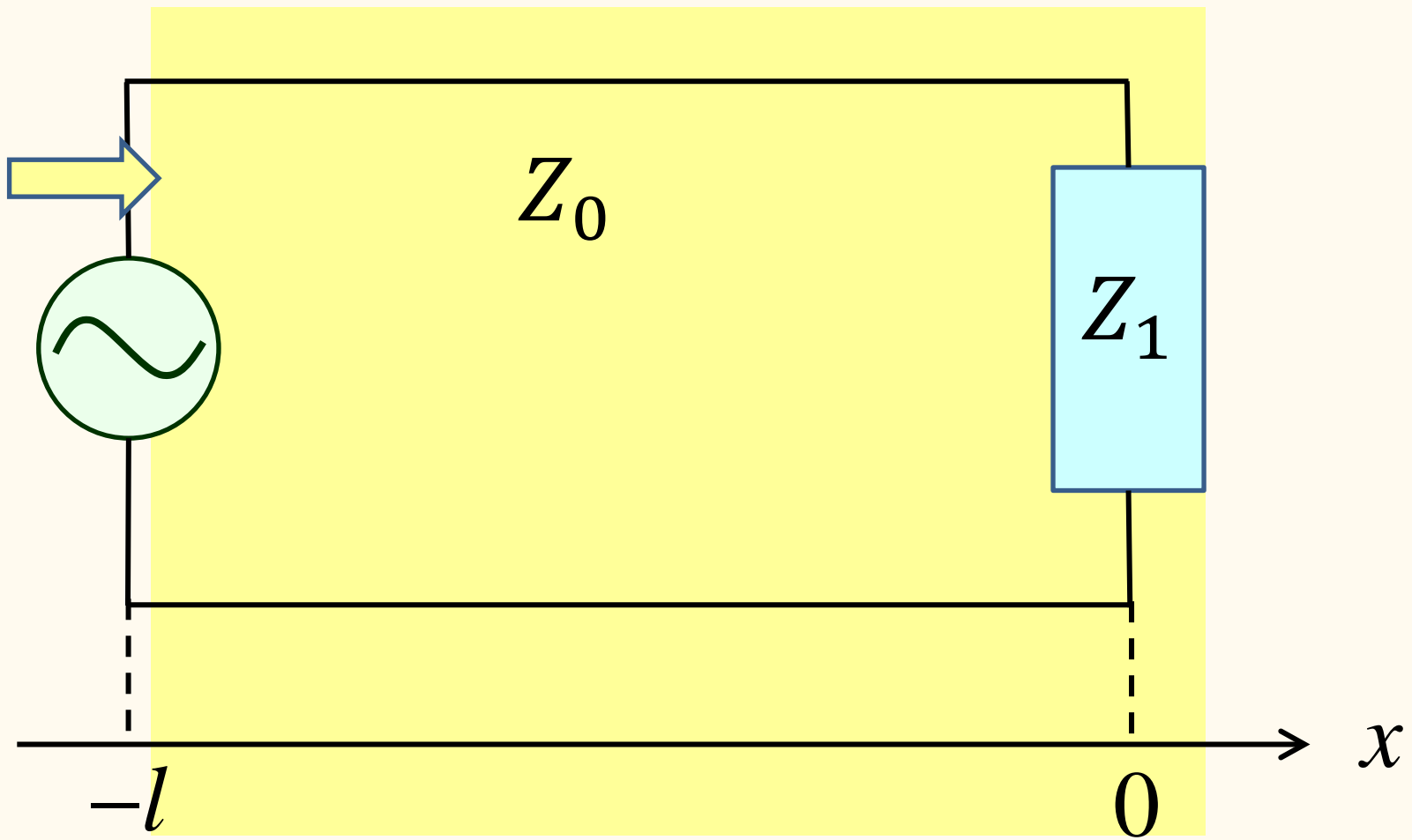

Exercise 4-3

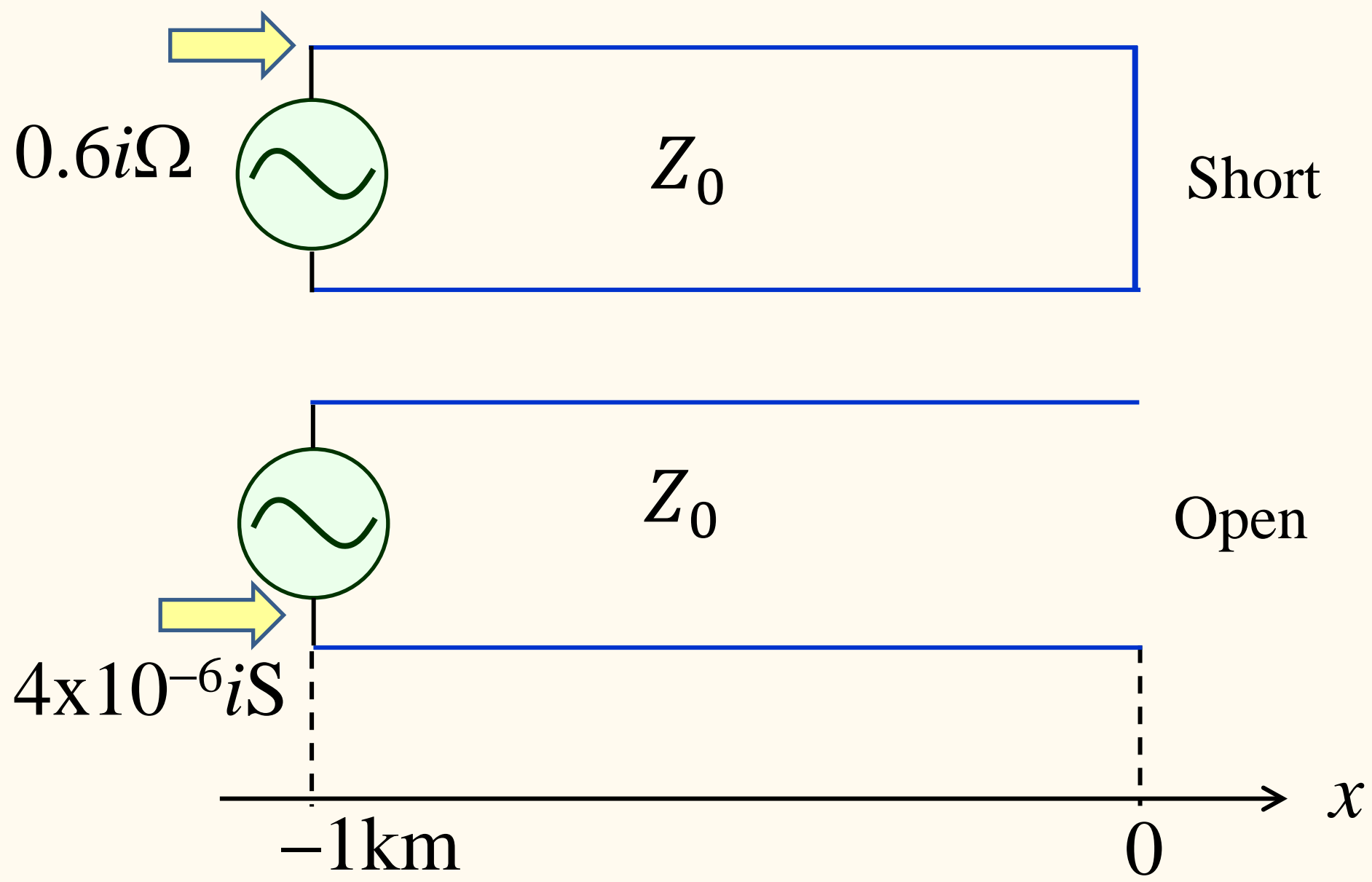

Connection and termination

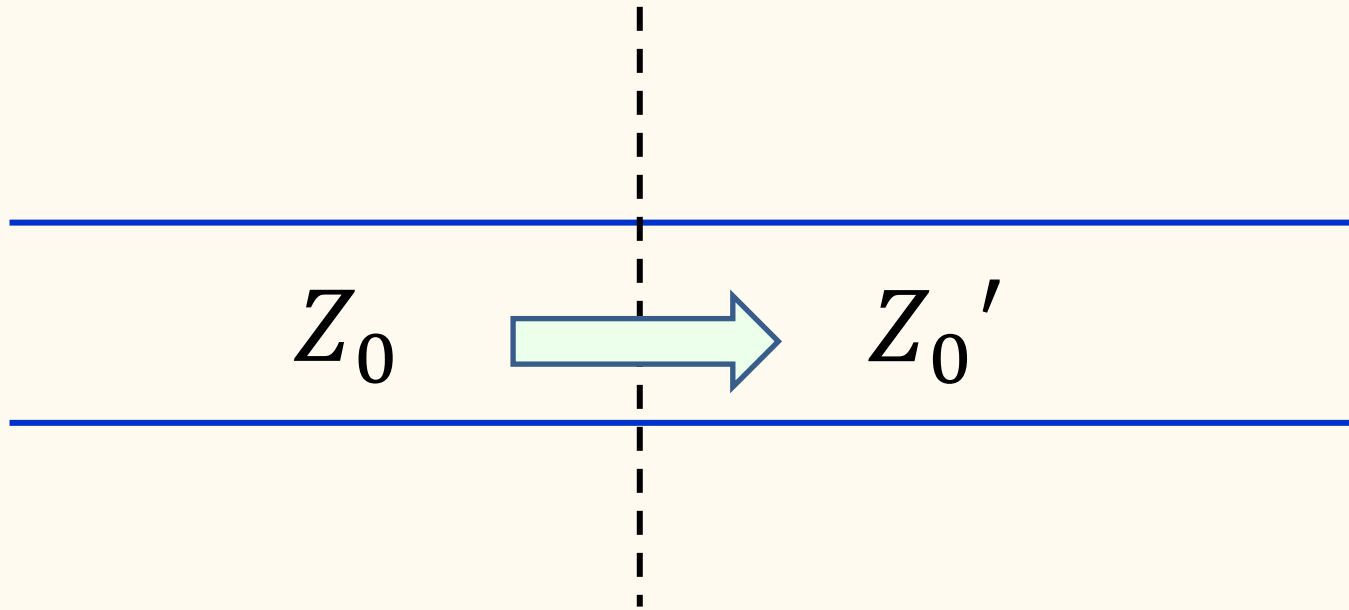

$$r = \frac{Z_0' - Z_0}{Z_0' + Z_0}$$

5.2.3 Smith chart, Immittance chart

r : reflection coefficient

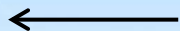

$$r = \frac{V_-}{V_+} = \frac{Z - Z_0}{Z + Z_0}$$

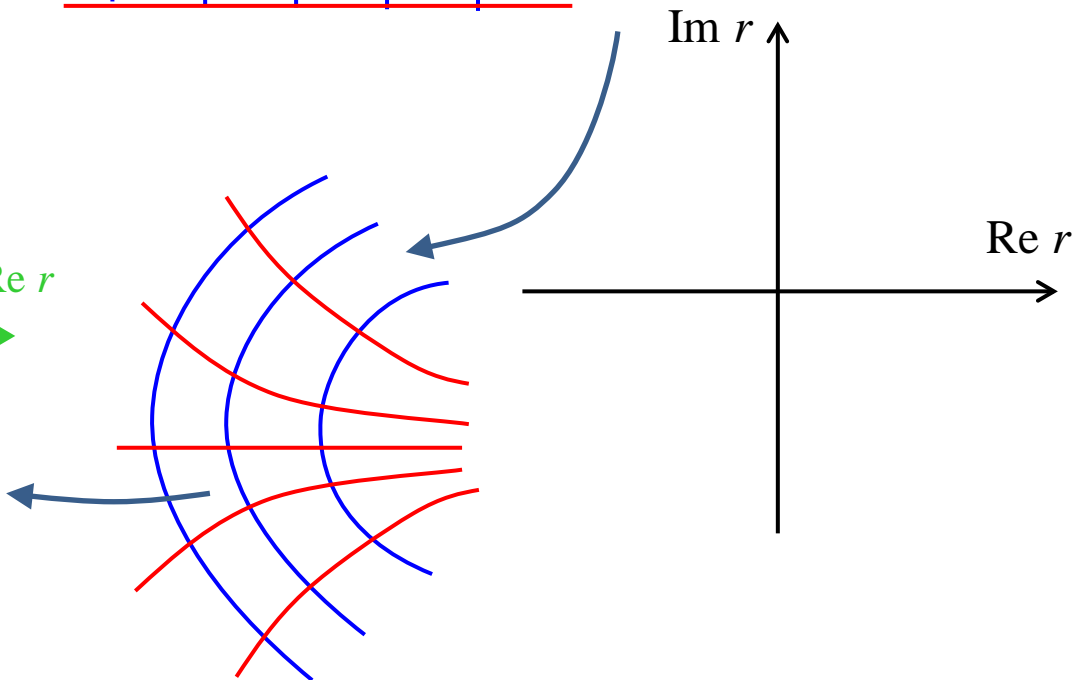
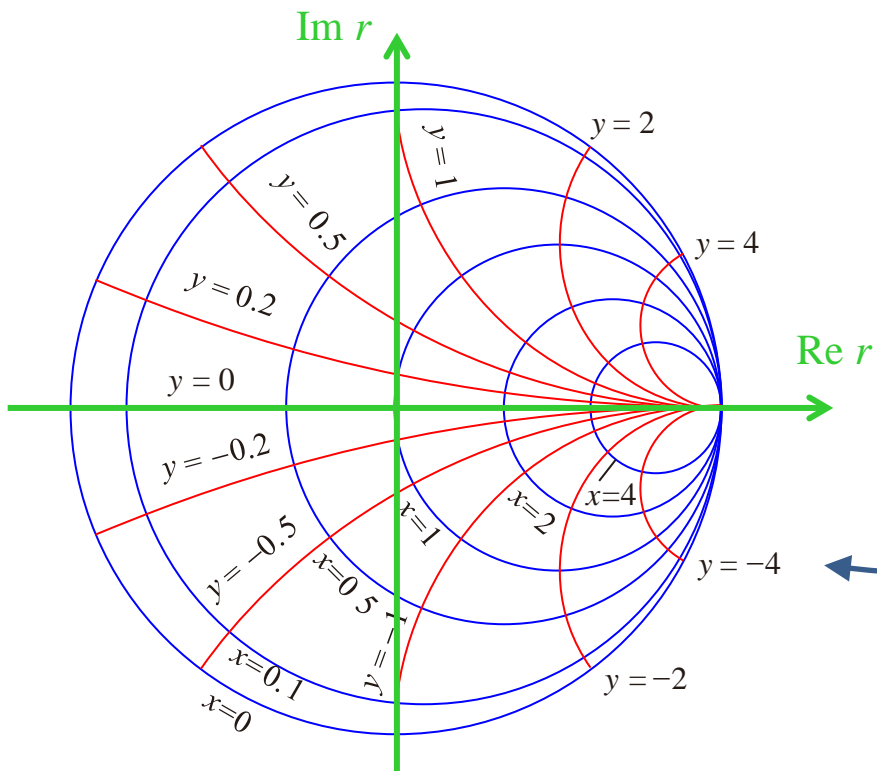
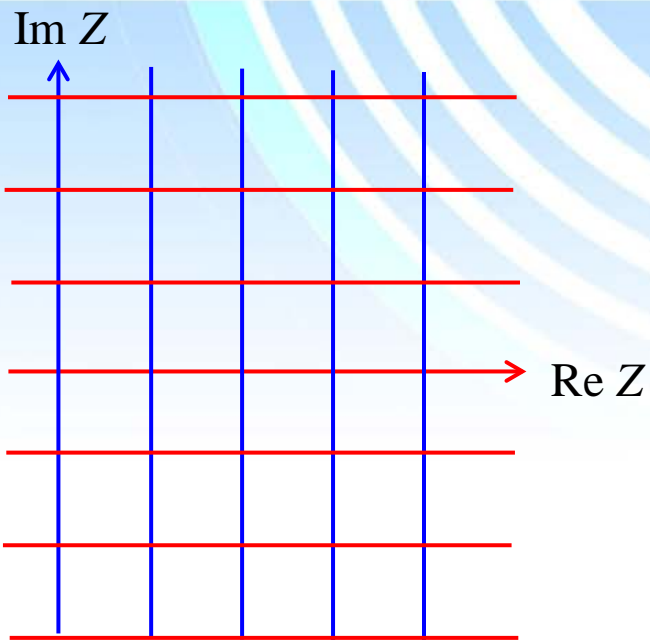
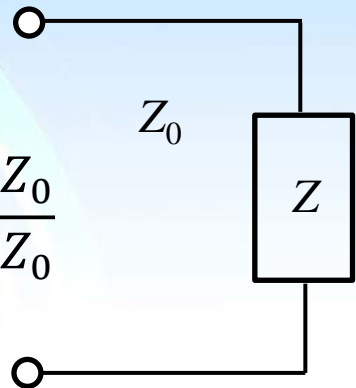

5.2.3 Smith chart, Immittance chart

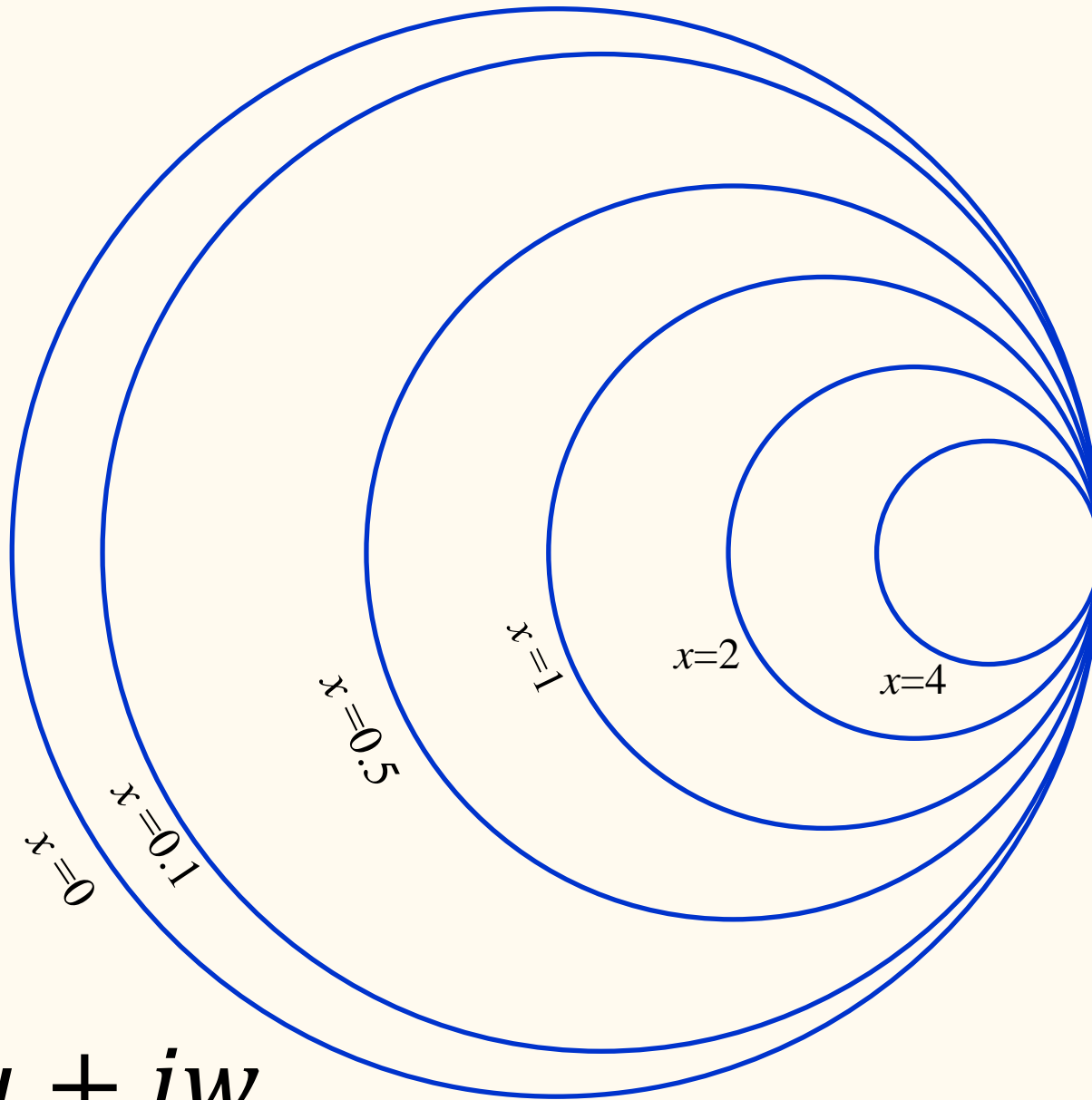

$$r = u + iw$$

5.2.3 Smith chart, Immittance chart

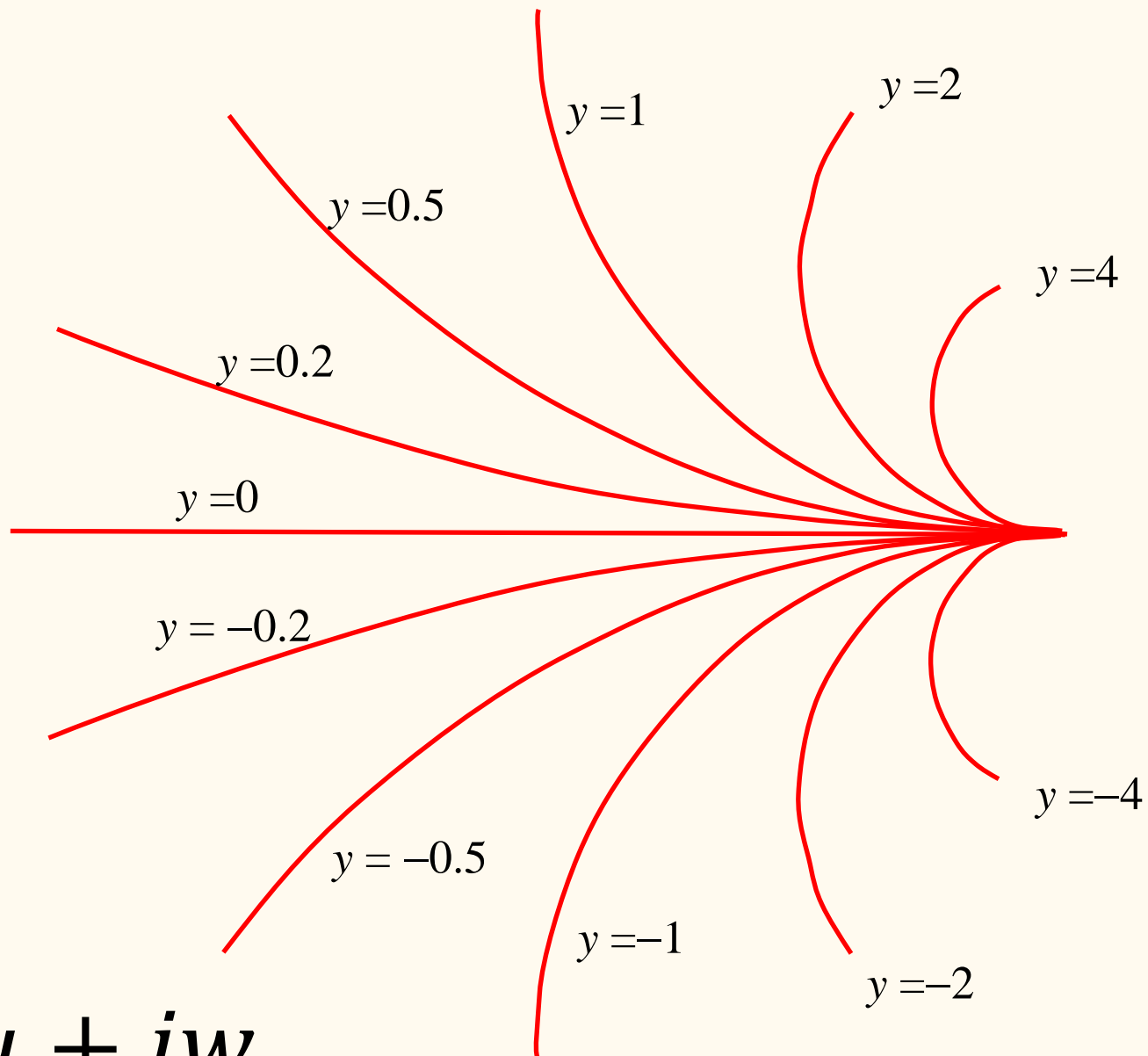

$$r = u + iw$$

5.2.3 Smith chart, Immittance chart

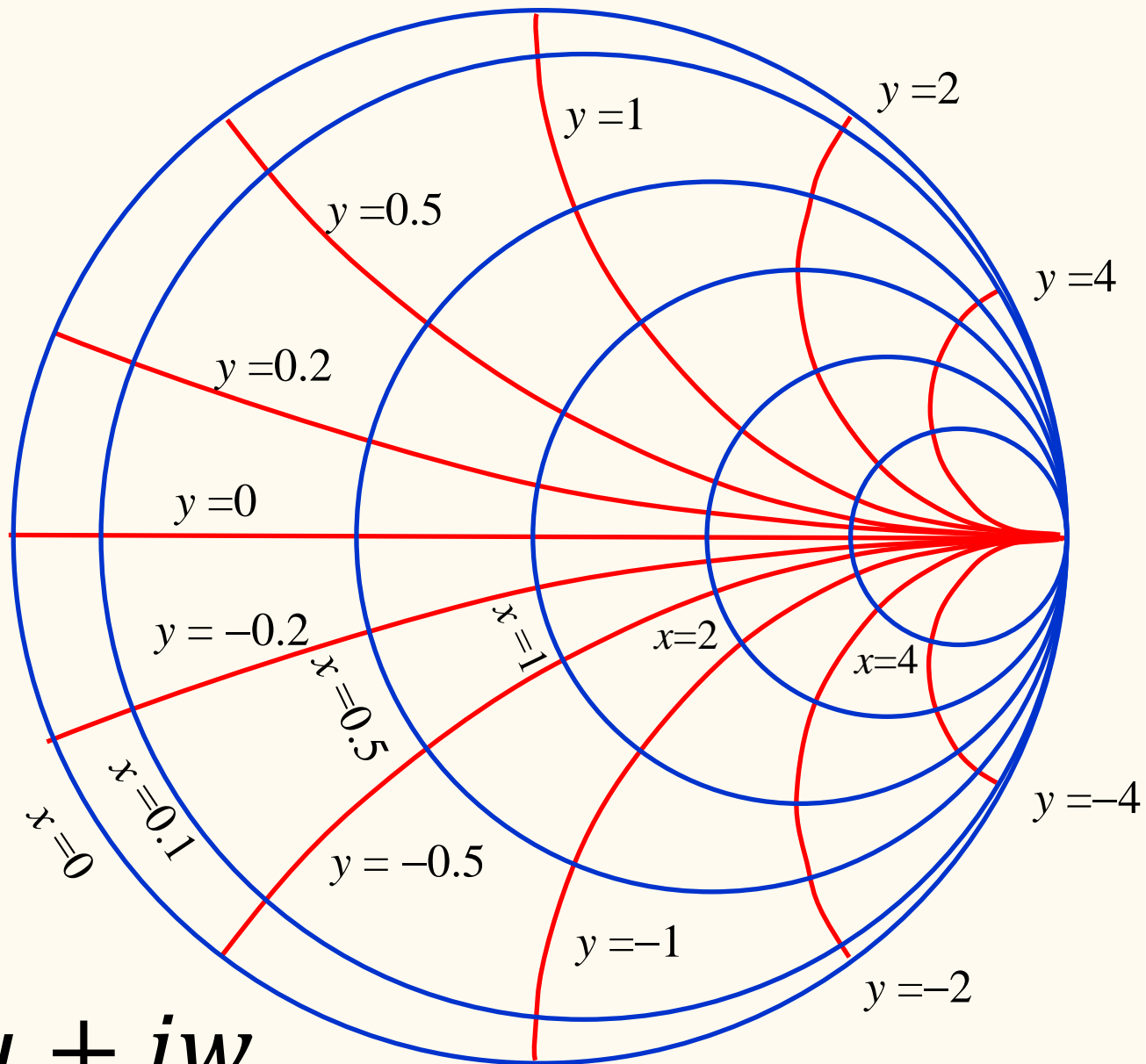

$$r = u + iw$$

Smith chart

5.2.3 Smith chart, Immittance chart

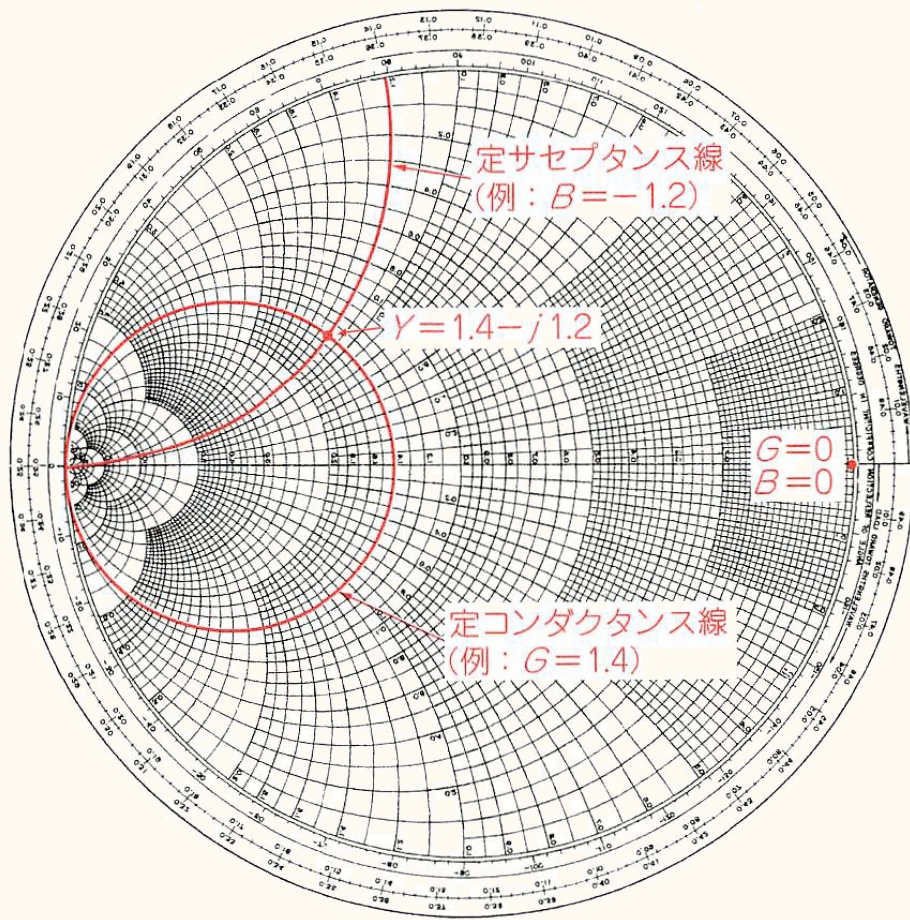

Admittance chart

$$r = u + iw$$

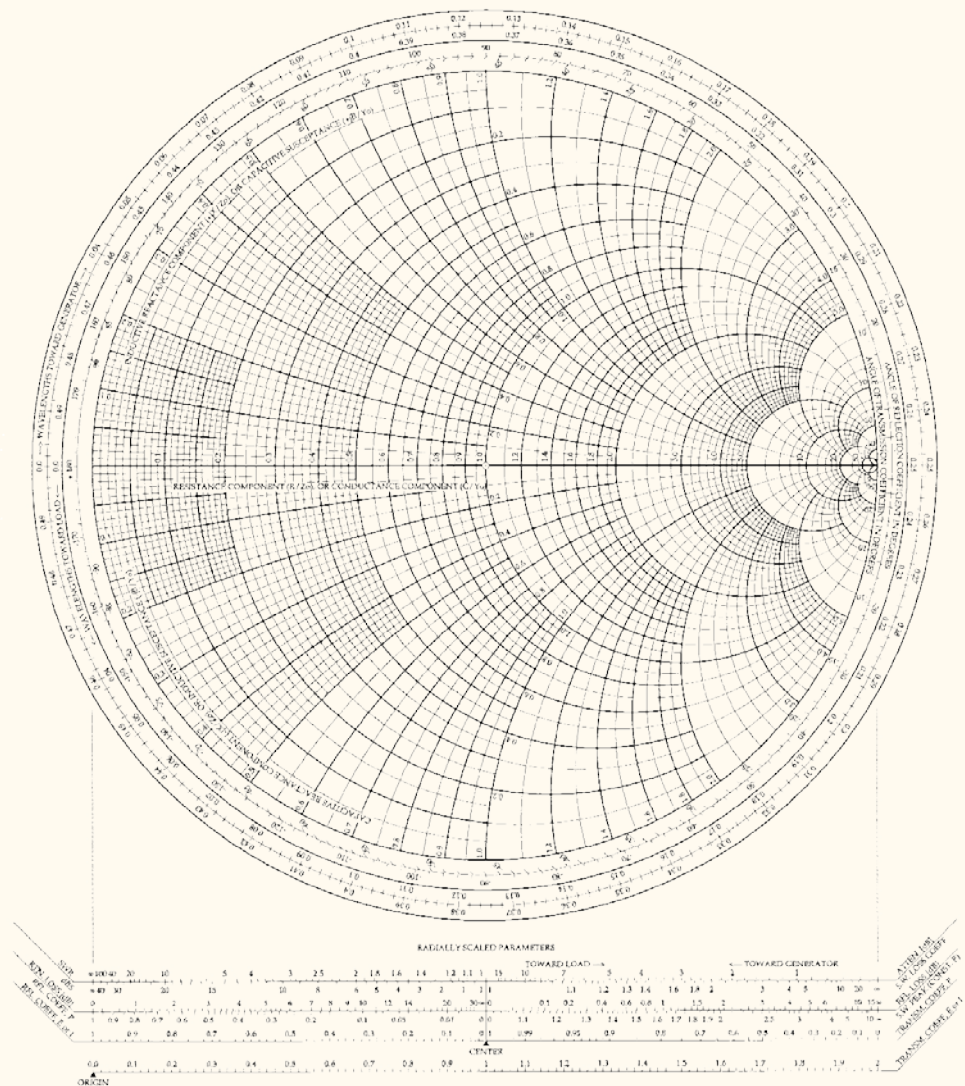

Smith chart

5.2.3 Smith chart, Immittance chart

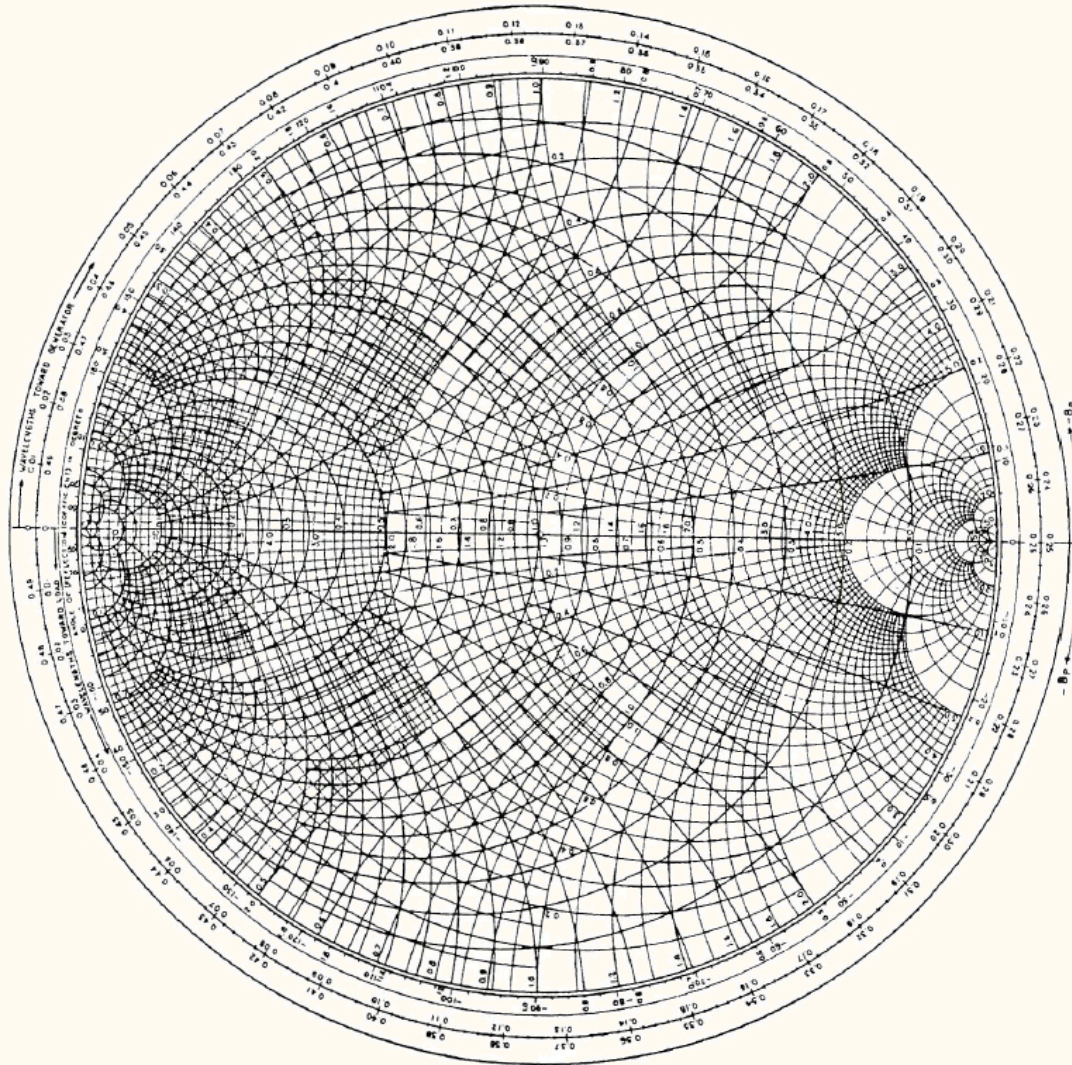

Immittance chart

$$r = u + iw$$

5.3 S matrix (S parameters)

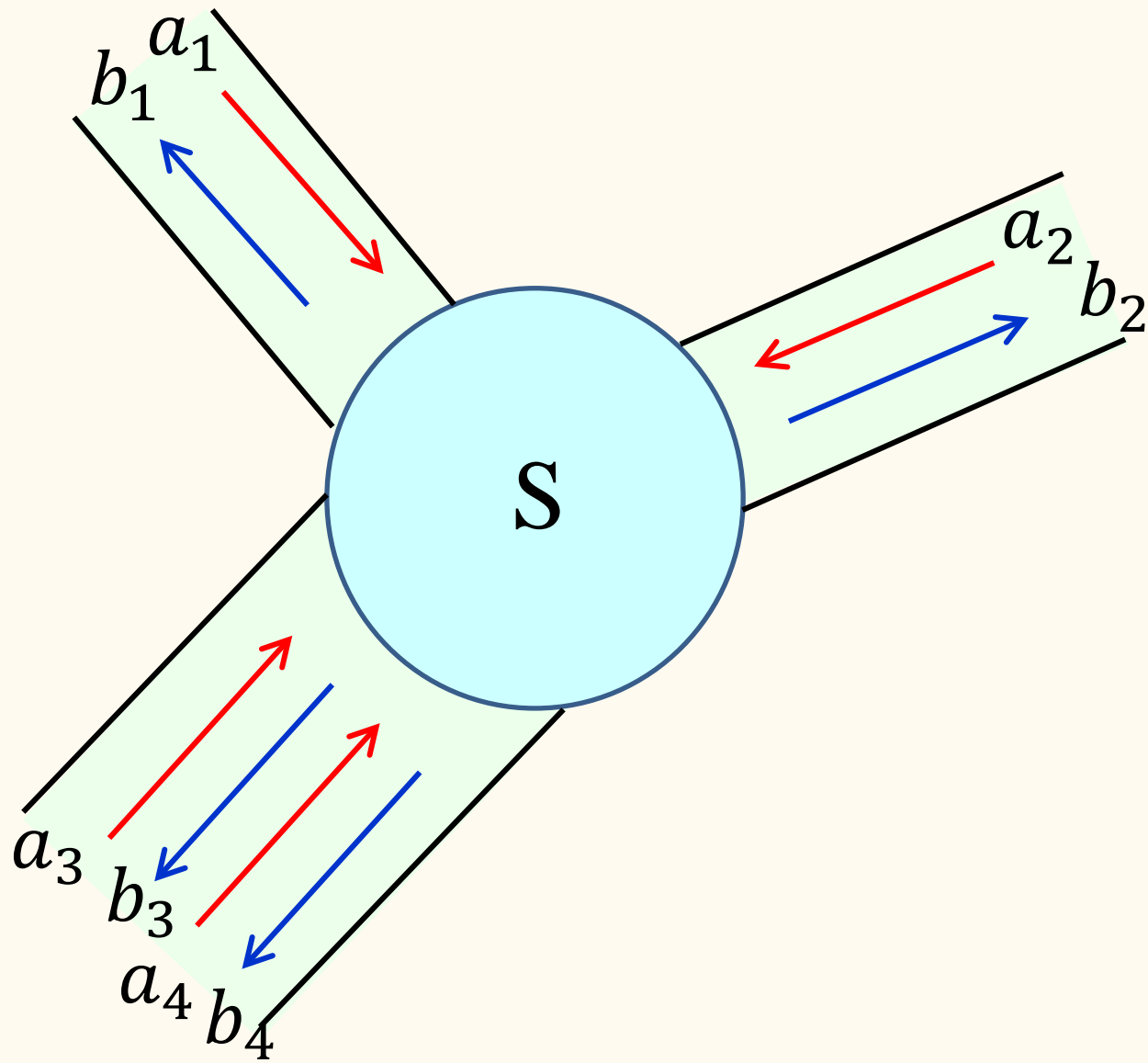

5.3 S-matrix (S-parameters)

Simplest case:

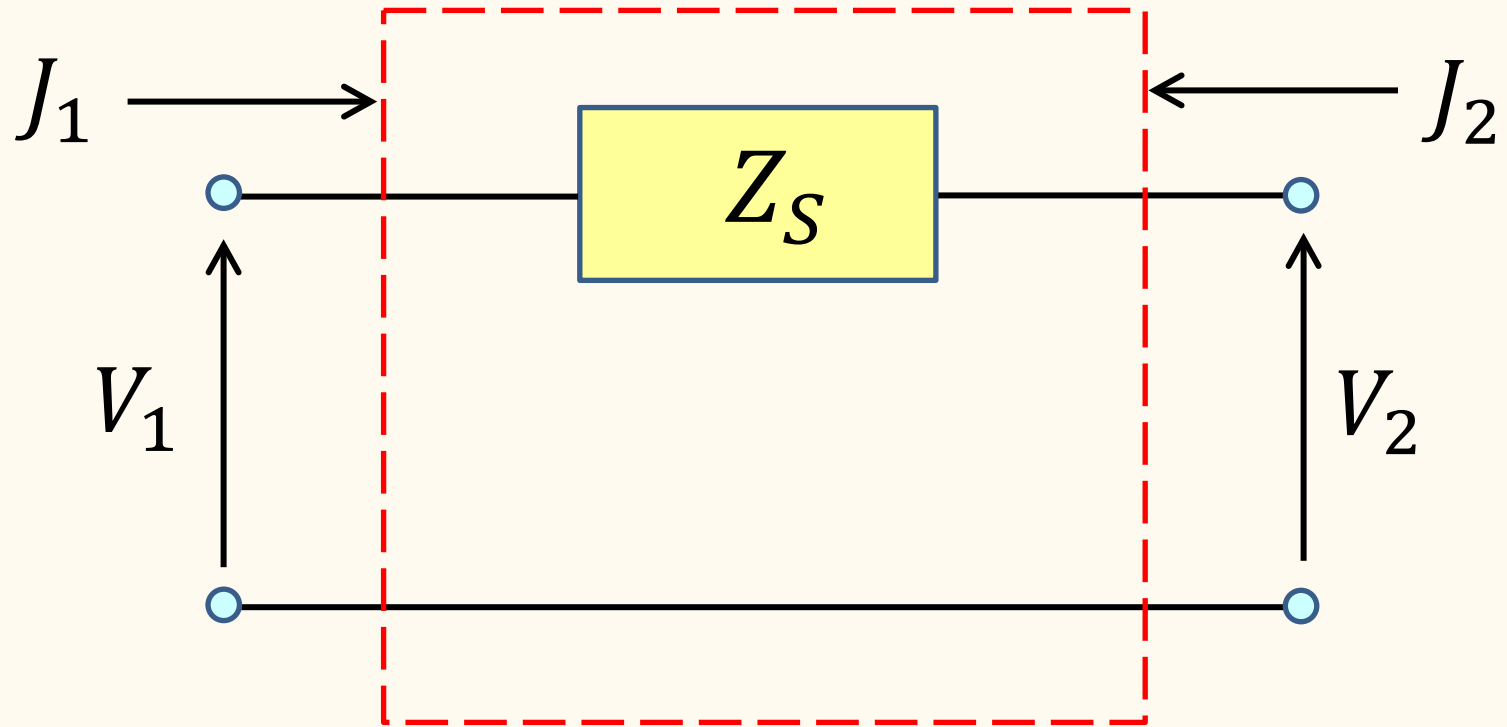

5.3 S-matrix (S-parameters)

Simplest case:

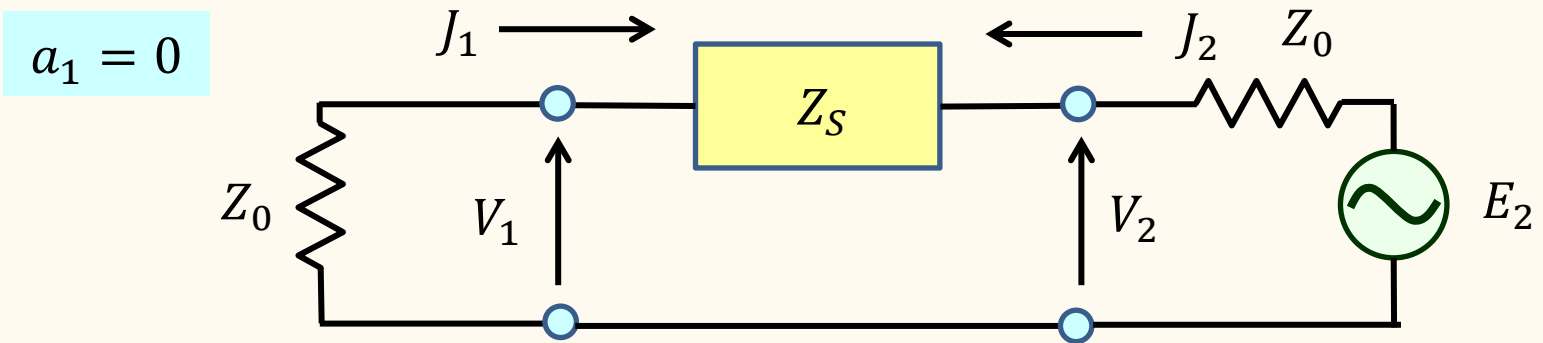
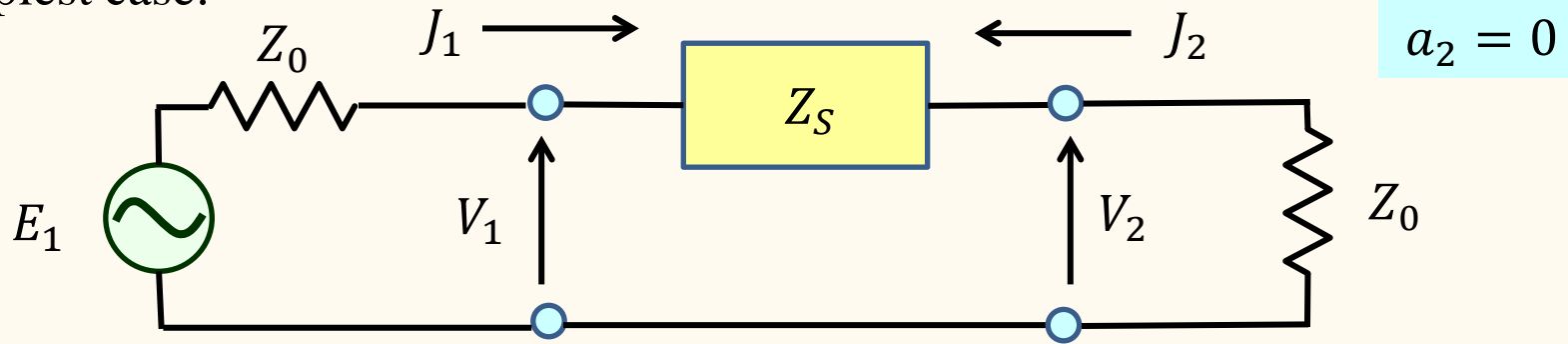

Cascade connection of S-matrices

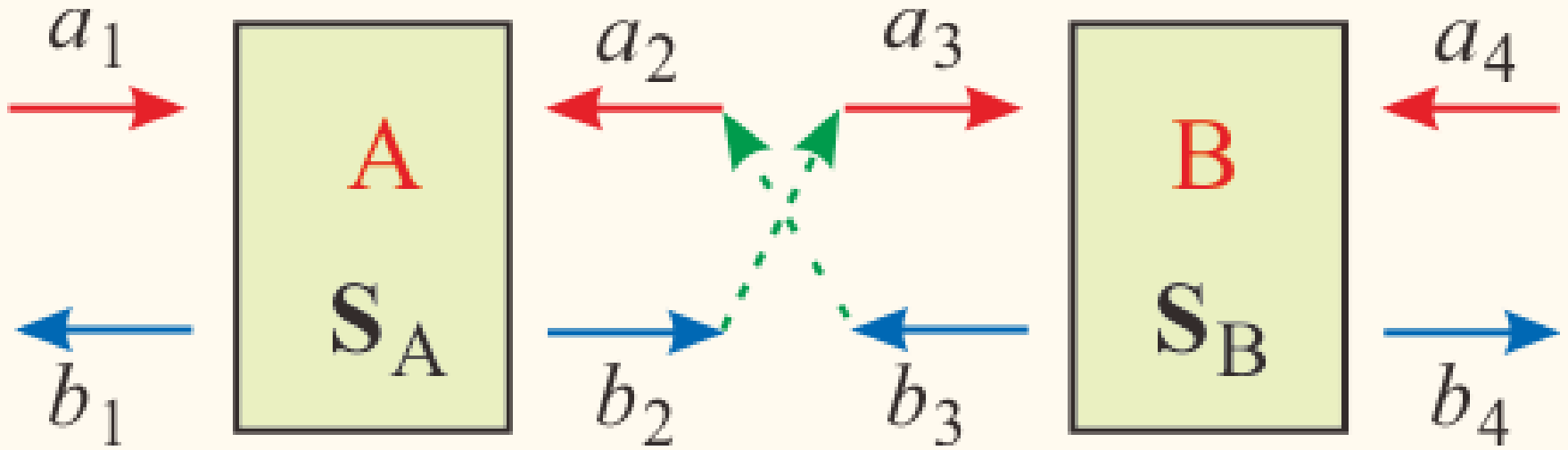
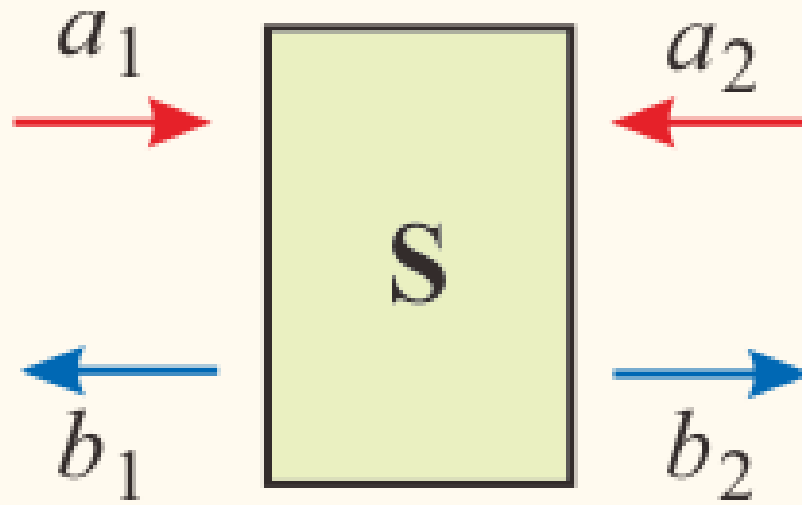

S-parameter representation of high-frequency devices

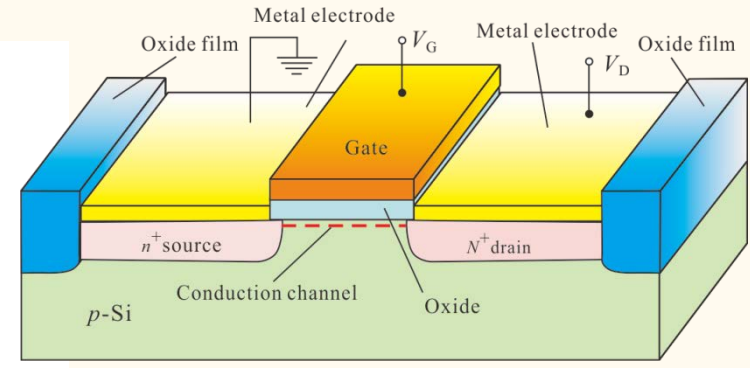
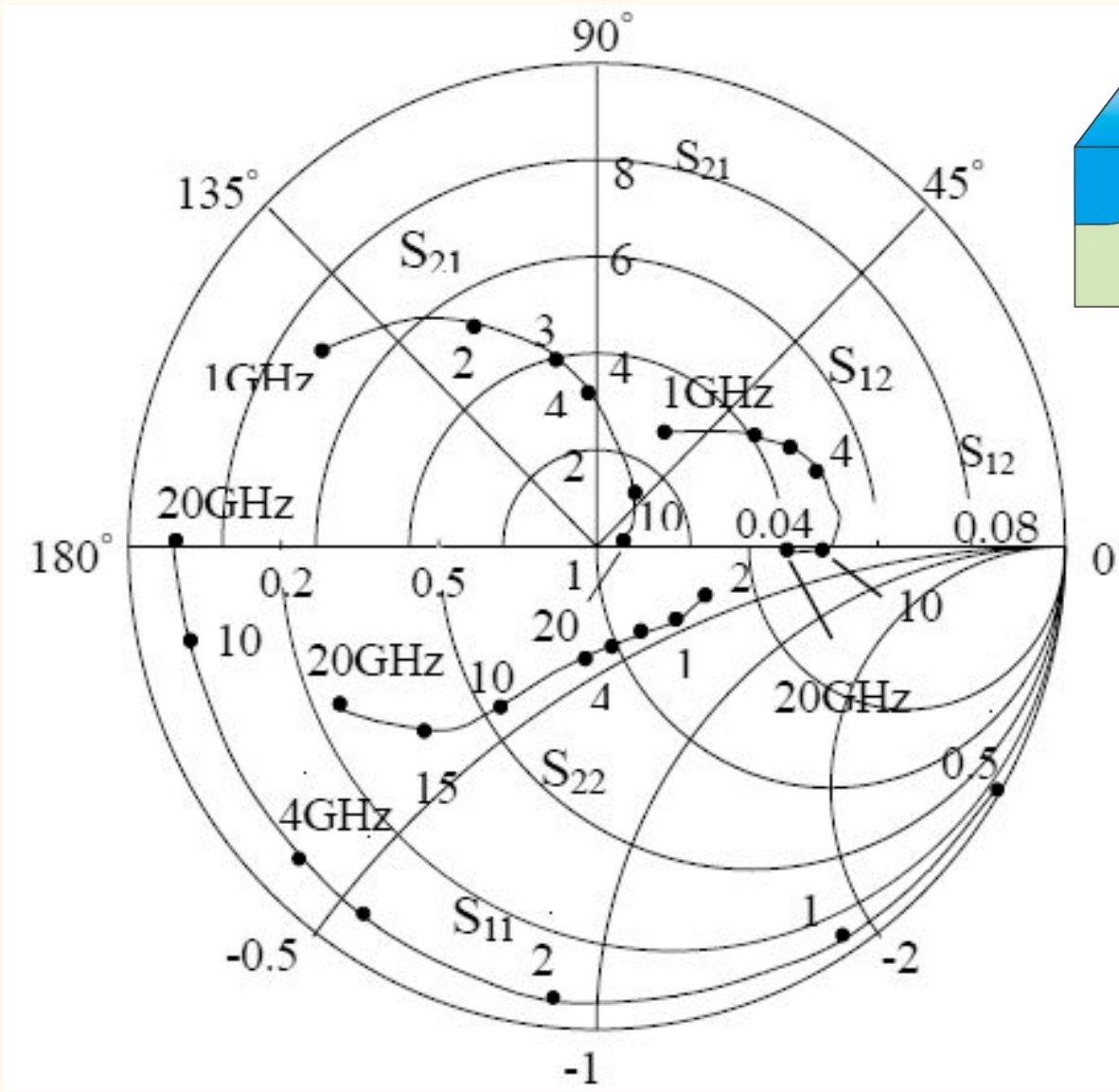

S-parameter representation of high-frequency devices

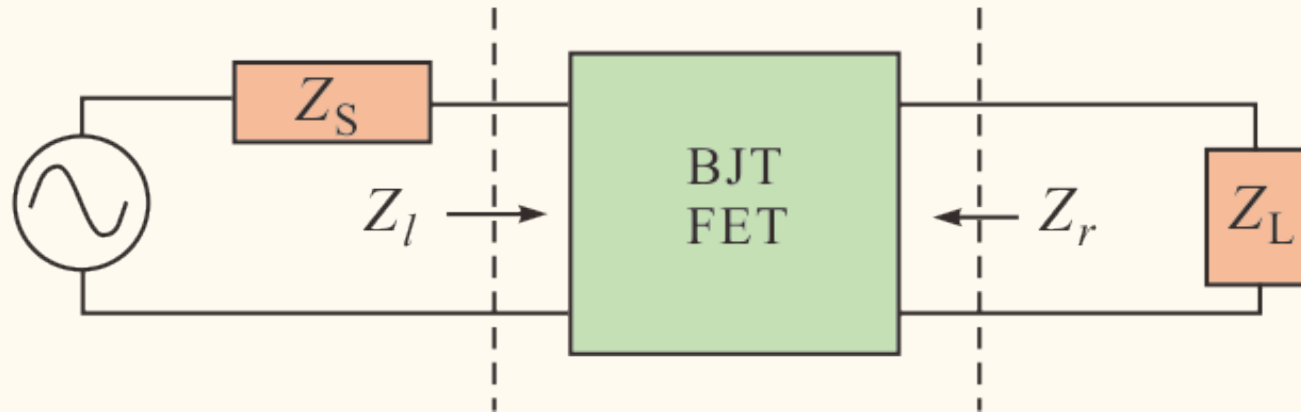
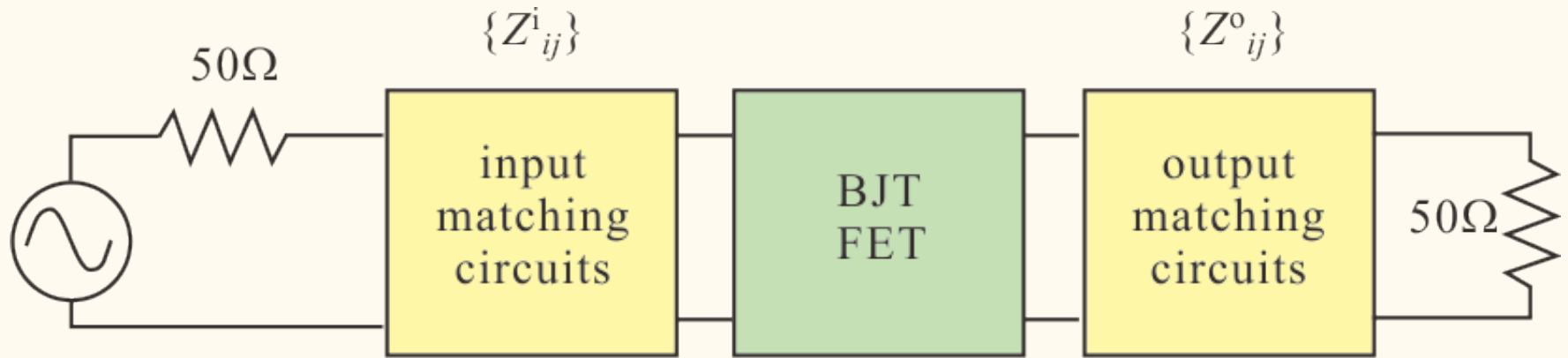

S-parameter representation of high-frequency devices



NEC	DATA SHEET
	GaAs MES FET NE76084
C to Ku BAND LOW NOISE AMPLIFIER N-CHANNEL GaAs MES FET	

S-PARAMETERS

$V_{DS} = 3\text{ V}$, $I_D = 10\text{ mA}$
START 500 MHz, STOP 18 GHz, STEP 500 MHz

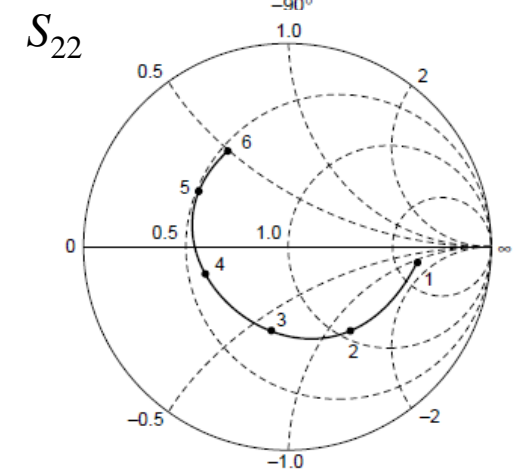
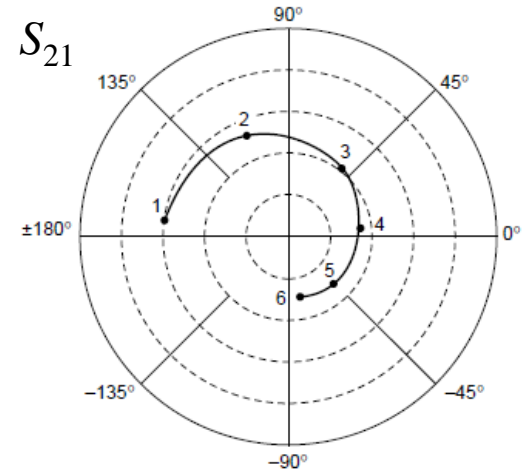
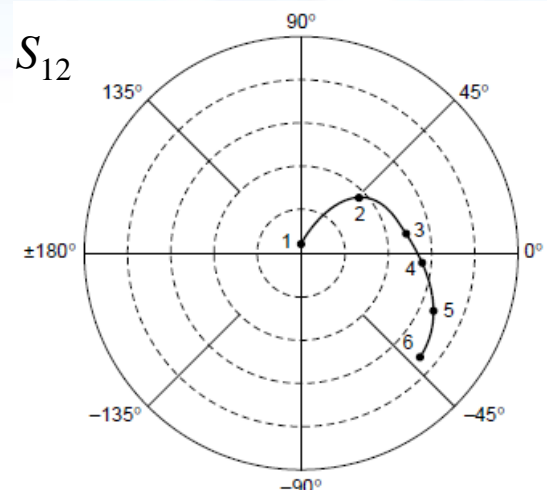
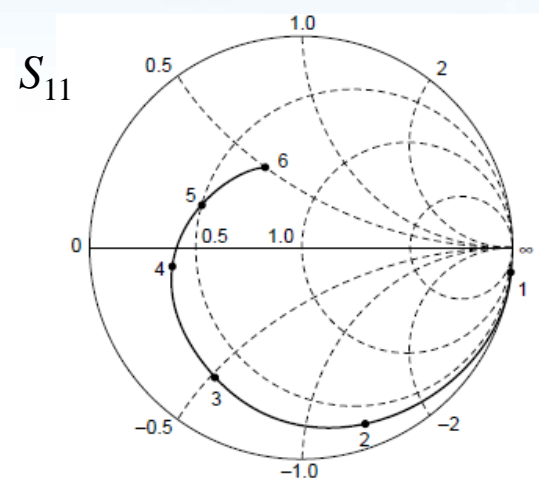

S-parameter and impedance matching

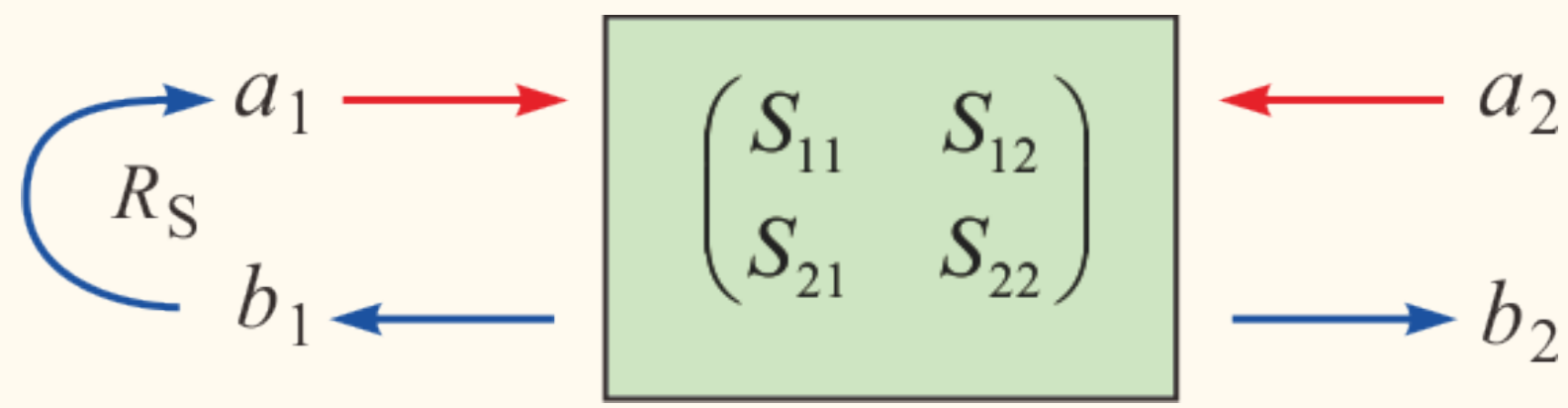
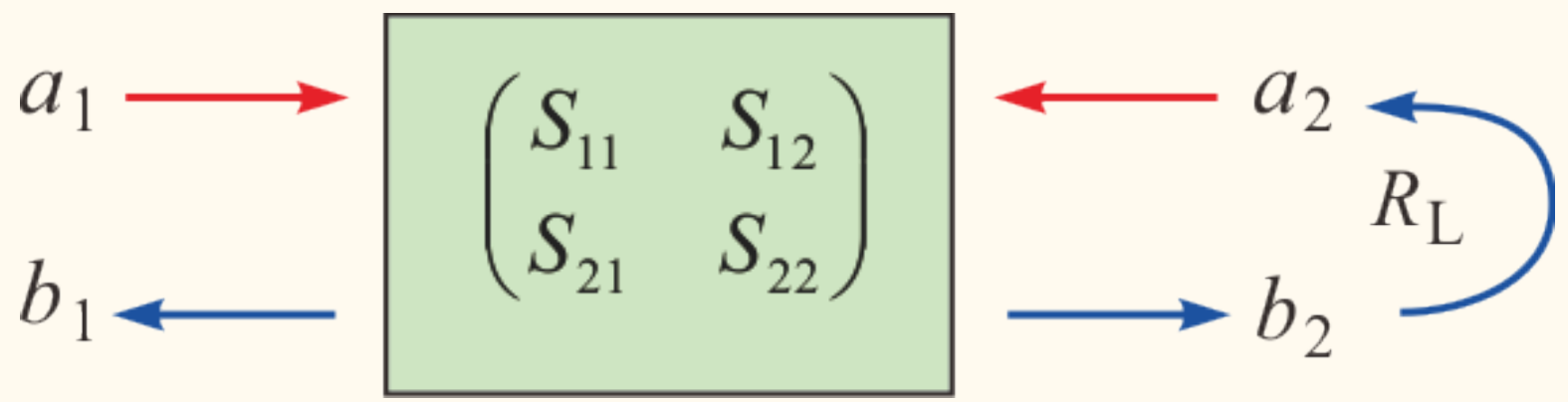

Practical impedance matching with Simth chart

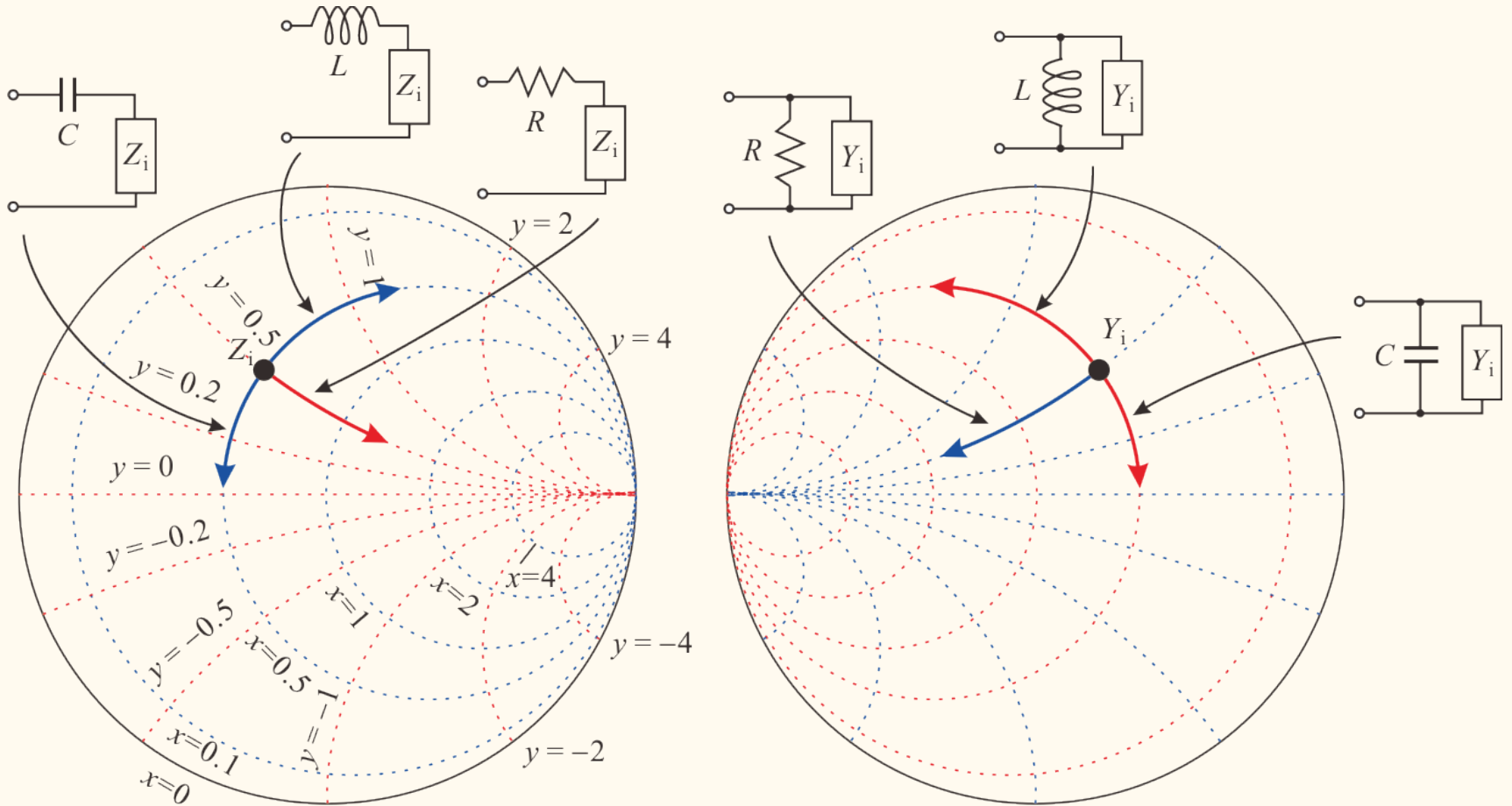

5.4 Giving mass to LC transmission line

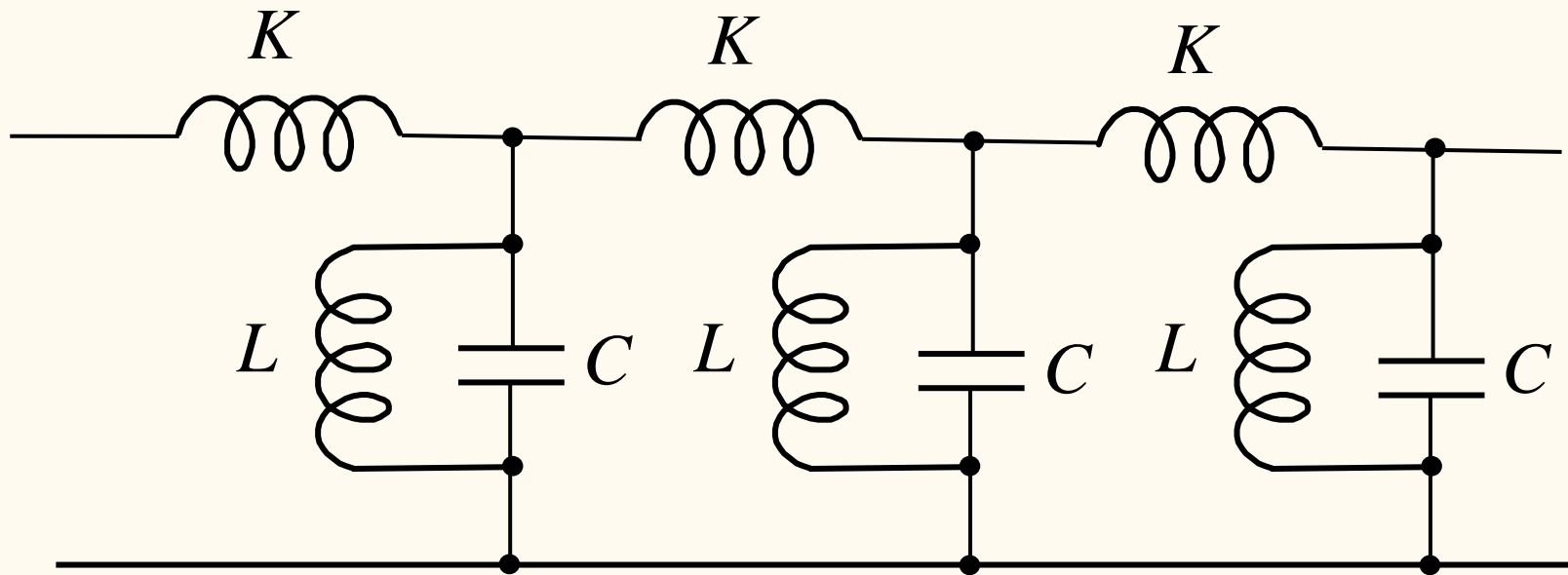

5.4 Giving mass to LC transmission line

